



PFD DIRECT DRIVE CONDENSER FAN

Daltec's PFD fan is right at home in all OEM Condenser Fan applications. Standard equipment includes an adjustable pitch impeller, which allows for exact performance matching without the need for belts and pulleys. The PFD Condenser Fan impeller incorporates the most efficient combination of high air volume, low power consumption and low noise. A heavy gauge steel housing and performance enhancing deep drawn venturi are also standard fare. For appearance and protection we coat every unit with a durable powder coat paint.

Daltec ... making fans to fit your equipment

Design Features

- Cast aluminum or GRP construction
- Standard sizes 10" to 72" diameter
- 2 to 16 blade/hub combinations
- Adjustable pitch airfoil impeller
- Excellent sound performance
- 300 – 100,000 CFM
- Maintenance free

Optional Items

- ATEX motors
- Choice of colors
- Custom designs
- Oversized & hinged panels
- AMCA spark resistant construction
- Motor side and/or propeller side guard
- Stainless steel or aluminum construction
- TEFC, explosion proof, mill & chem motors
- Single phase, three phase, 50 HZ & 60 HZ
- Flat panel and ring type housings available



PFD DIRECT DRIVE CONDENSER FAN

Trouble making that off the shelf fan fit, Daltec has the solution.

Panel Fan Dimensions (inches)						
Model	A	B	C	E	F	T
DPF12	12.5	16	13	2.5	1.5	16 ga.
DPF18	18.75	22	19	2.5	1.5	14 ga.
DPF21	21.75	25	22	4	1.5	14 ga.
DPF24	24.875	28	25	4	1.5	14 ga.
DPF27	27.875	32	29	4	1.5	14 ga.
DPF30	31	36	33.25	4	2	14 ga.
DPF36	36.875	42	39.25	4	2	14 ga.
DPF42	42.875	48	42.25	4.75	3	14 ga.
DPF48	48.875	54	51.25	5	3	14 ga.
DPF54	55	60	N/A	5.5	4	12 ga.

Dimensions are preliminary and are not to be used for construction.
Please contact Daltec: (888) 532-5832 for exact dimensional details.

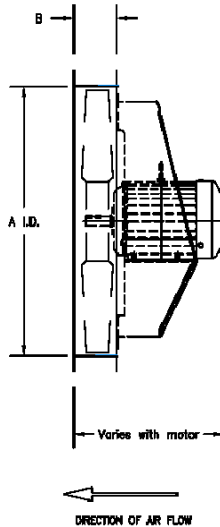
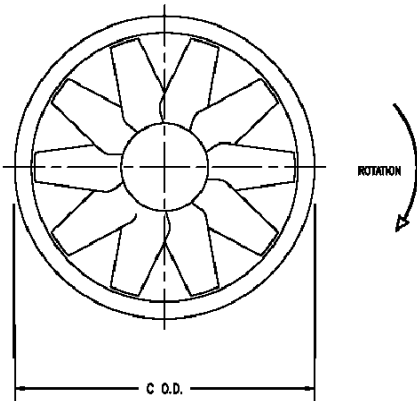
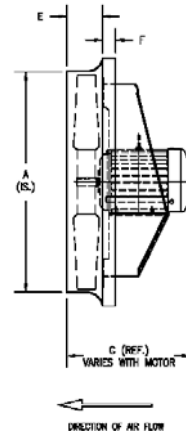
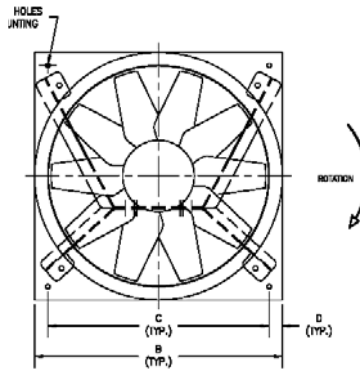

Flange Fan Dimensions (inches)			
Model	A	B	C
DFF12	12.25	4	15
DFF18	18.25	4	22
DFF21	21.25	4	24.5
DFF24	24.25	4	27.5
DFF27	27.25	4	31
DFF30	30.25	4	34
DFF36	36.25	4	40

Also Available From Daltec

Custom GPI Pressure Blowers & Fans



OEM Centrifugal & Axial Impellers



Heavy Duty Exhaust Fans & Blowers



Mixed Flow Fans & Impellers



For complete performance ratings and/or quotation, please contact your local Daltec sales representative or call (888) 5DALTEC (532-5832) for assistance

Optional Items and Accessories

- Weatherproof
- High Temperature Designs
- Reversible Designs
- Plastic Impellers
- Aluminum Impellers
- Aluminum Housings
- Heavy Duty Box Designs
- Standard Designs
- Custom Units
- Propeller Side OSHA Guard
- Motor Side OSHA Guard
- OEM Oriented

Daltec can customized many of the dimensions to fit your specific need. Even with small quantities, customization can be as cost effective as off the shelf. Give us a call and to see what we can do.

Daltec ... working with you.



Canada:
Daltec Industries Ltd.
Guelph, Ontario, N1E 5V5
Tel: (519) 837-1921
Toll Free: (888) 532-5832
faninfo@daltecfans.com
www.daltecfans.com

United States:
Daltec Industries Ltd.
Maple Grove, Minnesota, 55311
Toll Free: (888) 5Daltec
(888) 532-5832
wdimarco@daltecfans.com
www.daltecfans.com



MEMBER